

Transformer Oil Dissolved Gas Analyzer

The transformer monitor uses state of the art gas chromatography technology to accurately measure critical fault gases trapped within the transformer cooling oil. This data is monitored on a continuous basis, and is then correlated with electric system parameters. The information gives system operators early notification of a variety of incipient fault events that can lead to transformer failure. At the heart of this system is a custom designed gerotor pump developed by Cascon.



Pump Description:

A gerotor pump with integral 24-vdc brushless dc drive motor rated for 1000 ml/min at 3600 rpm and 80 psig. Critical design features include a canned rotor design that eliminates the rotary shaft seal thus the possibility of leaks, a manifold mount with SAE o-ring ports, a 8-pole neodymium brushless dc motor for a long maintenance-free life, rotor speed feedback that can be used for closed-loop servo control, a hardened steel shaft supported by journal bearings, housings machined from heat treated aluminum alloy, and Teflon impregnated hard anodized finish for superior corrosion protection and durability in harsh environments.

Selected Performance Data:

Fluid	Shell Diala AX
Flow Rate	250 cc/min
Temperature Range	-15°C to +120°C
Operating Pressure	50 psid
Operating Speed	750 rpm
Operating Voltage	24 vdc
MTBF	40,000 hours
Duty Cycle	Continuous



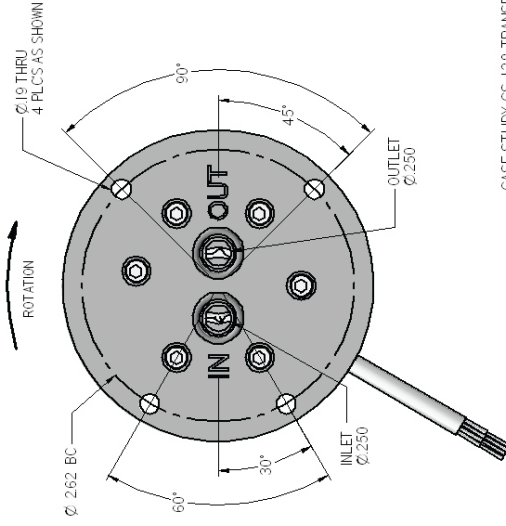
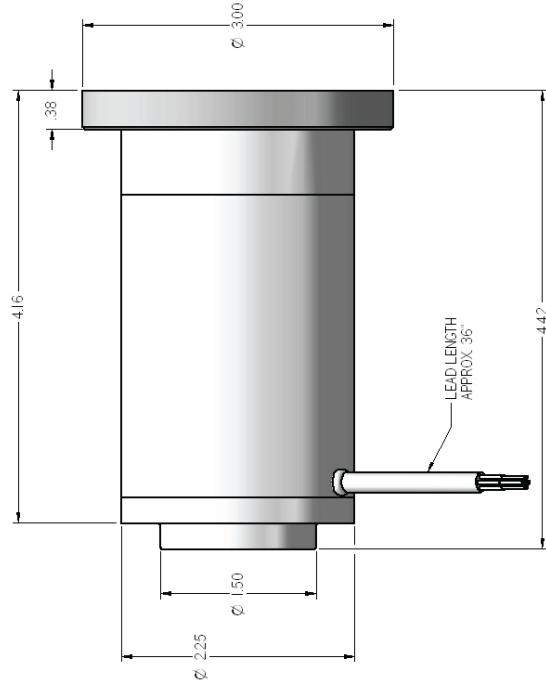
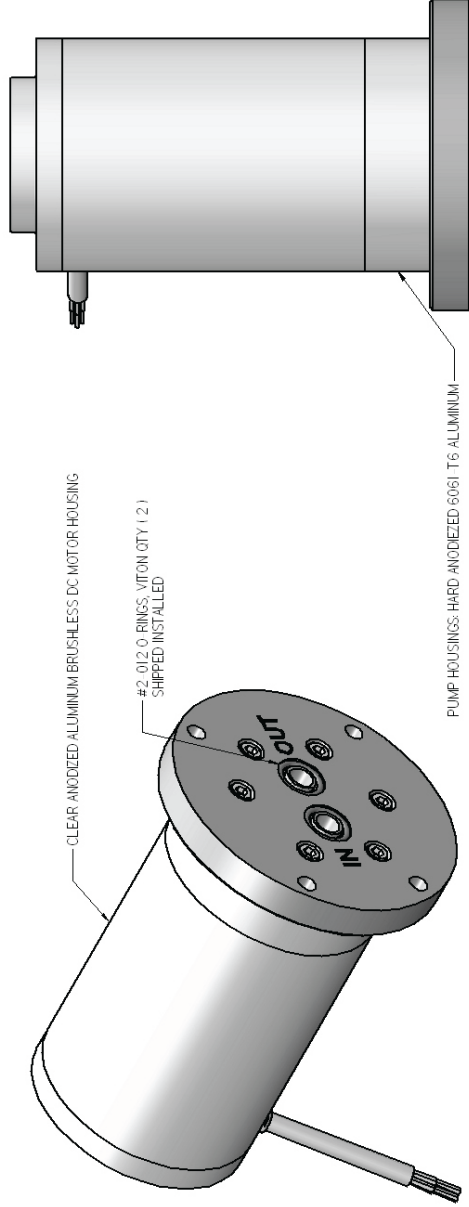

CASE STUDY CS-138 TRANSFER PUMP-61 COREV, 24VDC